

## No-Slack® Top Plate Installation

This Technical Bulletin supercedes Technical Bulletins TB-0293 and TB-001. It covers the replacement of an existing Fontaine No-Slack® 5000 & 5092 series fifth wheel with the new No-Slack® Top Plate (both the standard and air actuated).

When replacing an old style Fontaine fifth wheel with the new No-Slack® you will need to modify your mounting bracket by removing the rocker block as shown in figure 1 (next page). A 1" square by 3-1/8" replacement block is included with your new No-Slack®. Find the style and mounting height of your fifth wheel in Table 1 below to determine the height of the rocker block required. Shorten the rocker block as shown in the table. Mounting heights of 8" and above do not require rocker blocks.

Install your No-Slack® and locate the new rocker block as shown in Figure 2 for your model fifth wheel.

With your No-Slack® installed, locate the new rocker block as shown in the various model configurations in Figure 2 (page ). Tack weld the block and tilt the fifth wheel forward to make sure it contacts the new rocker block and clears all parts of the locking system. Check and make sure there is no interference with the air cylinder (if air operated fifth wheel) or the latching mechanism in a slide. Weld the rocker block in place.

**Table 1**

Mounting Style	Mounting Height	Rocker Block Height
Adjustable Flat Plate (AFP)	6-3/4"	2-3/8"
	7-3/4"	3-1/8"
Air & Manual Slide (AWB, AWS,& MWS)	6-3/4"	1-1/2"
	7-3/4"	2"
Angle Mount (A36)	6-1/4"	1-1/2"
	7-1/4"	2"
D3 Frame Mount	6-3/8"	2-3/8"
	7-3/8"	3-1/8"
Frame Mount (FMA)	6-3/8"	2-3/8"
	7-3/8"	3-1/8"

**Figure 1**

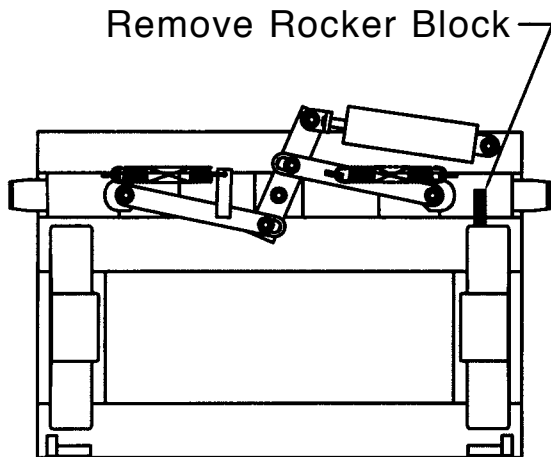

**AWB Slide**

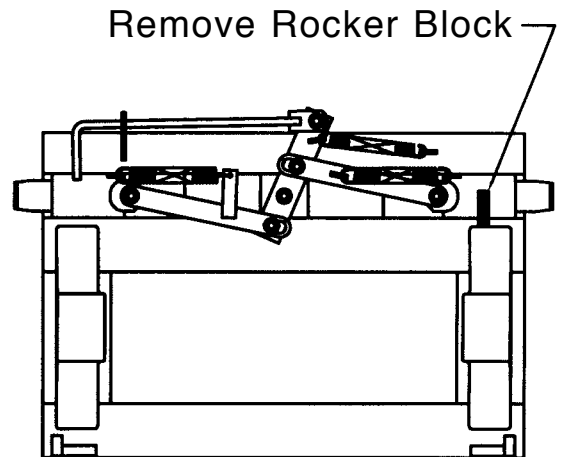

**MWS Slide**

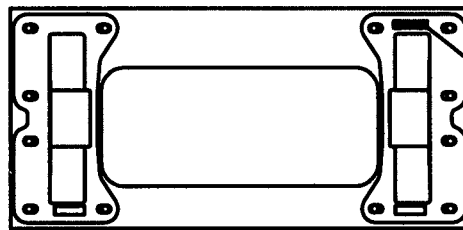

**Fifth Wheel AFP & FMA Style Brackets**

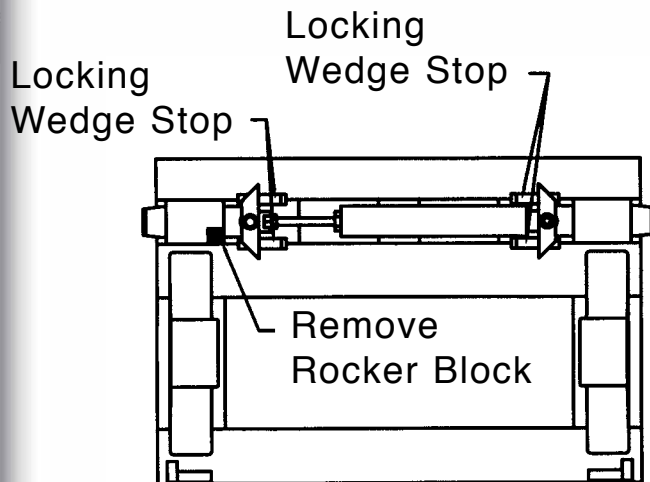

**AWS Slide**

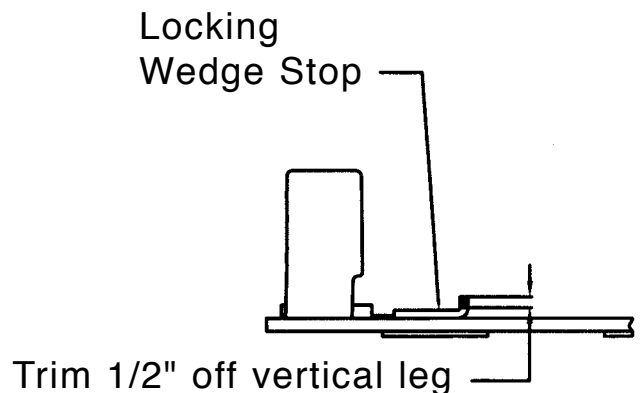

**AWS Slide**

**Figure 2**

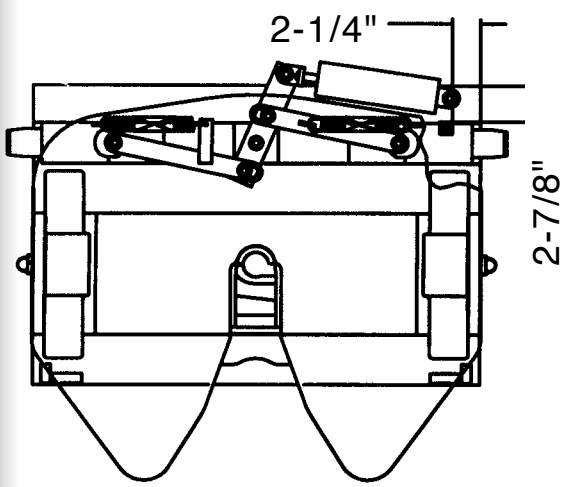

**Air Slide (AWB) or Manual Slide (MWS)**

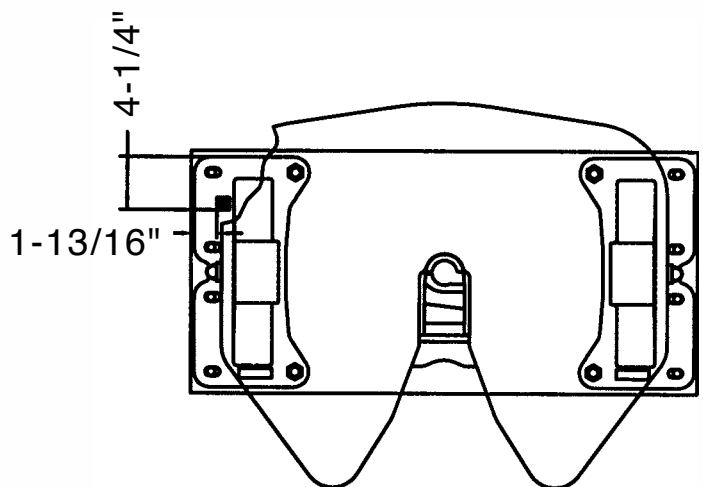

**Adjustable Flat Plate (AFP)**

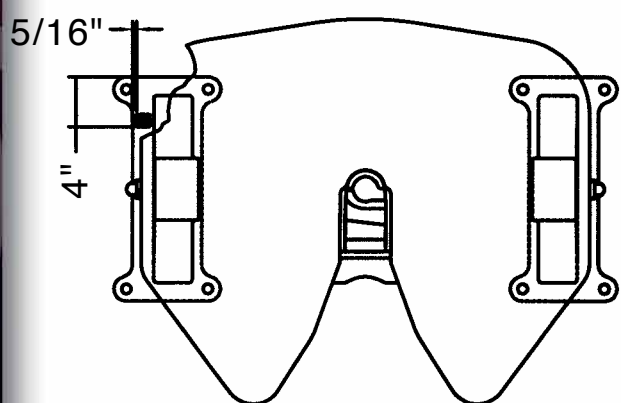

**D3 Frame Mount**

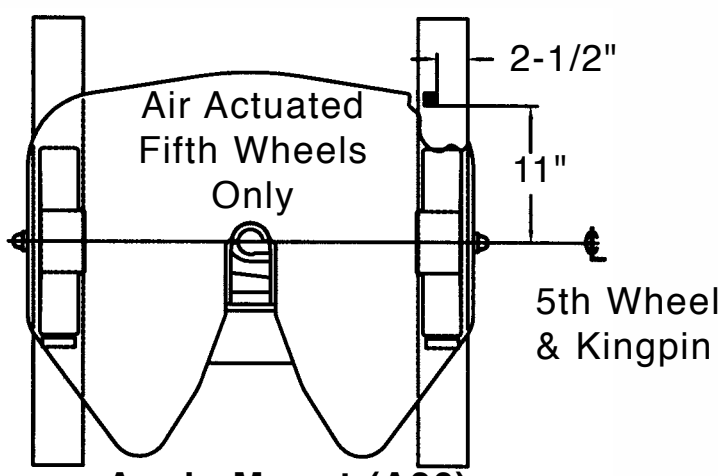

**Angle Mount (A36)**

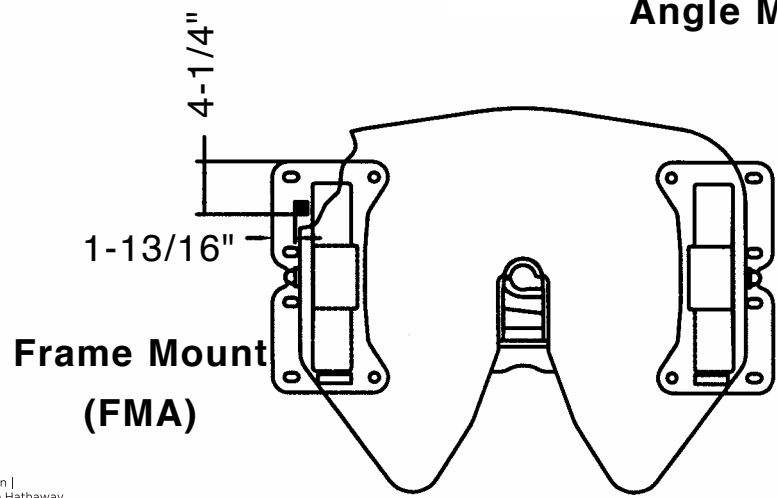

**Frame Mount (FMA)**